

TB 9-4931-501-35

CHANGE 6

DEPARTMENT OF THE ARMY TECHNICAL BULLETIN

CALIBRATION PROCEDURE FOR OSCILLOSCOPE TEKTRONIX, TYPES 5403D40, 5440, 5441, R5440, AND R5441

Headquarters, Department of the Army, Washington, DC
21 June 2001

TB 9-4931-501-35, 1 October 1979, is changed as follows:

1. Remove old pages and insert new pages as indicated below. New or changed material is indicated by a vertical bar in the margin of the page.

Remove pages

1 and 2

7 and 8

Insert pages

1 and 2

7 and 8

2. File this change sheet in front of the publication for reference purposes.

By Order of the Secretary of the Army:

ERIC K. SHINSEKI
General, United States Army
Chief of Staff

OFFICIAL:

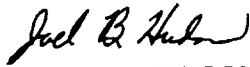

JOEL B. HUDSON
Administrative Assistant to the
Secretary of the Army

0116206

Distribution:

To be distributed in accordance with IDN 342067 requirements for calibration procedure TB 9-4931-501-35.

TB 9-4931-501-35

Change 5

DEPARTMENT OF THE ARMY TECHNICAL BULLETIN

CALIBRATION PROCEDURE FOR OSCILLOSCOPE TEKTRONIX, TYPES 5403D40, 5440, 5441, R5440, AND R5441

Headquarters, Department of the Army, Washington, DC

14 August 1989

TB 9-4931-501-35, 1 October 1979, is changed as follows:

1. Remove old pages and insert new pages as indicated below. New or changed material is indicated by a vertical bar in the margin of the page.

Remove pages

9 and 10

Insert pages

9 and 10

2. File this change sheet in front of the publication for reference purposes.

By Order of the Secretary of the Army:

CARL E. VUONO
General, United States Army
Chief of Staff

Official:

WILLIAM J. MEEHAN ii
Brigadier General, United States Army
The Adjutant General

Distribution:

To be distributed in accordance with DA Form 12-34C, Block No. 319, requirements for calibration procedures publications.

PIN NO.: 032019-005

TB 9-4931-501-35

Change 4

DEPARTMENT OF THE ARMY TECHNICAL BULLETIN

CALIBRATION PROCEDURE FOR OSCILLOSCOPE TEKTRONIX, TYPES 5403D40, 5440, 5441, R5440, AND R5441

Headquarters, Department of the Army, Washington, DC
3 July 1988

TB 9-4931-501-35, 1 October 1979, is changed as follows:

1. Remove old pages and insert new pages as indicated below. New or changed material is indicated by a vertical bar in the margin of the page.

Remove pages
9 and 10

Insert pages
9 and 10

2. File this change sheet in front of the publication for reference purposes.

By Order of the Secretary of the Army:

CARL E. VUONO
General, United States Army
Chief of Staff

Official:

R. L. DILWORTH
Brigadier General, United States Army
The Adjutant General

Distribution:

To be distributed in accordance with DA Form 12-34C, Block No. 319, requirements for calibration procedures publications.

PIN NO.: 032019-004

TB 9-4931-501-35

Change 3

DEPARTMENT OF THE ARMY TECHNICAL BULLETIN

CALIBRATION PROCEDURE FOR OSCILLOSCOPE TEKTRONIX, TYPES 5403D40, 5440, 5441, R5440, AND R5441

Headquarters, Department of the Army, Washington, DC
19 October 1987

TB 9-4931-501-35, 1 October 1979, is changed as follows:

1. Remove old pages and insert new pages as indicated below. New or changed material is indicated by a vertical bar in the margin of the page.

Remove pages
7 through 10

Insert pages
7 through 10

2. File this change sheet in front of the publication for reference purposes.

By Order of the Secretary of the Army:

CARL E. VUONO
General, United States Army
Chief of Staff

Official:

R. L. DILWORTH
Brigadier General, United States Army
The Adjutant General

Distribution:

To be distributed in accordance with DA Form 12-34C, Block No. 319, requirements for calibration procedures publications.

PIN NO.: 032019-003

TB 9-4931-501-35

Change 2

DEPARTMENT OF THE ARMY TECHNICAL BULLETIN

CALIBRATION PROCEDURE FOR OSCILLOSCOPE TEKTRONIX, TYPES 5403D40, 5440, 5441, R5440, AND R5441

Headquarters, Department of the Army, Washington, DC

20 February 1985

TB 9-4931-501-35, 1 October 1979, is changed as follows:

1. Remove old pages and insert new pages as indicated below. New or changed material is indicated by a vertical bar in the margin of the page.

Remove pages

3 and 4

9 and 10

Insert pages

3 and 4

9 and 10

2. File this change sheet in front of the publication for reference purposes.

By Order of the Secretary of the Army:

JOHN A. WICKHAM, JR.
General, United States Army
Chief of Staff

Official:

DON J. DELANDRO
Brigadier General, United States Army
The Adjutant General

Distribution:

To be distributed in accordance with DA Form 12-34C, Block No. 319, requirements for calibration procedures publications.

PIN NO.: 032019-002

TB 9-4931-501-35

Change 1

DEPARTMENT OF THE ARMY TECHNICAL BULLETIN

CALIBRATION PROCEDURE FOR OSCILLOSCOPE TEKTRONIX, TYPES 5403D40, 5440, 5441, R5440, AND R5441

Headquarters, Department of the Army, Washington, DC

3 October 1980

TB 9-4931-501-35, 1 October 1979, is changed as follows:

1. . New or changed material is indicated by a vertical bar in the margin of the page.

Remove pages

1 and 2

Insert pages

1 and 2

2. File this change sheet in front of the publication for reference purposes.

By Order of the Secretary of the Army:

E. C. MEYER
General, United States Army
Chief of Staff

Official:

J. C. PENNINGTON
Major General, United States Army
The Adjutant General

Distribution:

To be distributed in accordance with DA Form 12-34A (qty rqr block no. 75), requirements for calibration procedures publications.

PIN NO.: 032019-001

***TB 9-4931-501-35**

DEPARTMENT OF THE ARMY TECHNICAL BULLETIN

CALIBRATION PROCEDURE FOR OSCILLOSCOPE TEKTRONIX, TYPES 5403D40, 5440 R544L, R5440, AND R5441

Headquarters, Department of the Army, Washington, DC

1 October 1979

REPORTING OF ERRORS

You can help improve this publication. If you find any mistakes or if you know of a way to improve the procedure, please let us know. Mail your letter or DA Form 2028 to: Commander, U. S. Army Aviation and Missile Command, ATTN: AMSAM-MMC-MA-NP, Redstone Arsenal, AL 35898-5230. A reply will be furnished to you. You may also send in your comments electronically to our e-mail address: 2028@redstone.army.mil or FAX 256-842-6546/DSN 788-6546.

SECTION		Paragraph	Page
	I. IDENTIFICATION AND DESCRIPTION		
	Test instrument identification	1	2
	Calibration data card, DA Form 2416.....	2	2
	Calibration description	3	2
	II. EQUIPMENT REQUIREMENTS		
	Equipment required	4	3
	Accessories required	5	3
	III. PRELIMINARY OPERATIONS		
	Preliminary instructions	6	4
	Equipment Setup	7	4
	IV. CALIBRATION PROCESS		
	Calibrator output voltage	8	7
	Intensity range	9	7
	Focus and astigmatism.....	10	8
	Trace alignment.....	11	8
	Geometry.....	12	9
	Vertical centering	13	10
	Vertical gain	14	10
	Vertical compensation.....	15	11
	Risetime	16	13

CHANGE 6

*This bulletin supersedes TB 9-4931-501-50, 28 August 1978.

	Paragraph	Page
Horizontal centering.....	17	13
Horizontal gain.....	18	14
10 and 5 ns timing.....	19	14
Readout system.....	20	16
Power supply.....	21	17
Final procedure.....	22	18

**SECTION I
IDENTIFICATION AND DESCRIPTION**

1. Test Instrument Identification. This bulletin provides instructions for the calibration of Oscilloscope, Tektronix Types 5403D40, 5440, 5441, R5440, and R5441. The manufacturer's manuals were used as the prime data source in compiling these instructions. The above equipment will be referred to as the TI (test instrument) throughout this bulletin.

a. Model Variations. None.

b. Time and Technique. The time required for this calibration is approximately 4 hours, using the dc (direct current) and low frequency technique.

2. Calibration Data Card, DA Form 2416

a. Forms, records, and reports required for calibration personnel at all levels are prescribed by TM 38-750. DA Form 2416 must be annotated in accordance with TM 38-750 for each calibration performed.

b. Adjustments to be reported on DA Form 2416 are designated (R) at the end of the sentence in which they appear. When adjustments are in tables, the (R) follows the designated adjustment. Report only those adjustments made and designated with (R).

3. Calibration Description. TI parameters and performance specifications which pertain to this calibration are listed in table 1.

Table 1. Calibration Description

Test instrument parameters	Performance specifications
Vertical amplifier: Bandwidth	Dc to 90 MHz (2/067-0680-00) Dc to 60 MHz (w/calibrated 5A48)
Risetime	3.9 ns or less (w/067-00680-00) ¹ 5.8 ns or less (w/calibrated 5A48)
Aberrations	6% or less (w/067-0680-00) 3% or less (w/calibrated 5A48)
Vertical centering	Within ± 0.5 division of graticule center
Horizontal amplifier: Bandwidth	Dc to 2 MHz

See footnote at end of table.

Table 1. Calibration Description - Continued.

Test instrument parameters	Performance specifications
Power input	100, 110, 120, 200, 220, and 240 Vrms ±10% at to 400 Hz
Calibrator:	
Voltage	400 mV ±1%
Current	4 mA, ±1%
Frequency	Twice the power line frequency

¹Time base plug-in limited to 4 ns.

SECTION II EQUIPMENT REQUIREMENTS

4. Equipment Required. Table 2 identifies the specific equipment used in this calibration procedure. This equipment is issued with -Secondary Transfer Standards Calibration Set NSN 6695-00-621-7877 and Secondary Reference Calibration Standards for NSN 4931-00-621-7878, and is to be used in performing this procedure. Alternate items may be used by the calibrating activity when the equipment listed in table 2 is not available. The items selected must be verified to perform satisfactorily prior to use and must bear evidence of current calibration. The equipment must meet or exceed the minimum use specifications listed in table 2.

5. Accessories Required. The accessories, listed in table 3 are issued as indicated in paragraph 4 above and are to be used in this calibration procedure. When necessary, these items may be substituted by equivalent items unless specifically prohibited.

Table 2. Minimum Specifications of Equipment Required

Item	Common name and/or official nomenclature	Minimum use specifications	Manufacturer, model and part number
A1	AUTOTRANSFORMER (TRANSFORMER, VARIABLE POWER)	Range: 105 to 125 V rms Accuracy: ±1%	General Radio, Model W10MT3AS3 (7910809)
A2	CALIBRATION FIXTURE	Range: 1 kHz to 1 MHz at 4 ns or less Accuracy: ±1%	Tektronix, Type 067-0680-00 (6625-01-014-6673)
A3	DIGITAL VOLTMETER W/HIGH VOLTAGE PROBE	Range: -3060 to +240 V dc Accuracy: ±0.1%	Dana, Model 5703-S-2127 (7912606)
A4	TIME BASE	Range: 10 ns/div and must be compatible with TI	Tektronix, Type 5B42 (MIS-28706-4)
A5	TIME MARK GENERATOR	Range: 5 and 10 ns Accuracy: ±1%	Tektronix, Type 184(7912042-1) ¹ Tektronix Type 184 MOD 146B (7912042-2) ²
A6	VERTICAL AMPLIFIER	Must be compatible with TI	Tektronix, Type 5A48 (MIS-28706-3)

¹Secondary Reference Set.

²Secondary Transfer Set.

Table 3. Accessories Required

Item	Common name and/or official nomenclature	Description and part number
B1	ADAPTER (CONNECTOR ADAPTER)	Single banana jack to alligator clip (black) (7907560)
B2	CABLE ¹	48-in., RG-58/U, BNC plug terminations (10519140)
B3	PROBE	Test hook to single banana plug (SKC-4850-14)
B4	ADAPTER	BNC plug to binding post (103-0033-00)

¹Two required.

SECTION III PRELIMINARY OPERATIONS

6. Preliminary Instructions

a. The instructions outlined in this section are preparatory to the calibration process. Personnel should become familiar with the entire bulletin before beginning the calibration.

b. Items of equipment used in this procedure are referenced within the text by common name and item identification number as listed in tables 2 and 3. For the identification of equipment referenced by item numbers prefixed with A, see table 2, and for prefix B, see table 3.

WARNING

HIGH VOLTAGE is used during the performance of this calibration. DEATH ON CONTACT may result if personnel fail to observe safety precautions.

7. Equipment Setup

- a.** Refer to figure 1 for location of TI circuit boards.
- b.** Remove top and bottom protective covers from TI. Insure that line selector block (brown) (fig. 2) for 120 V ac (volts alternating current) operation is installed.
- c.** Connect TI to autotransformer (A1).
- d.** Connect autotransformer to 115-V ac source and adjust output to 115 V ac.
- e.** Install vertical amplifier (A6) into TI left compartment and time base (A4) into right compartment.
- f.** Position TI controls as listed in (1) through (5) below:
 - (1) INTENSITY control ccw (counterclockwise) (off).

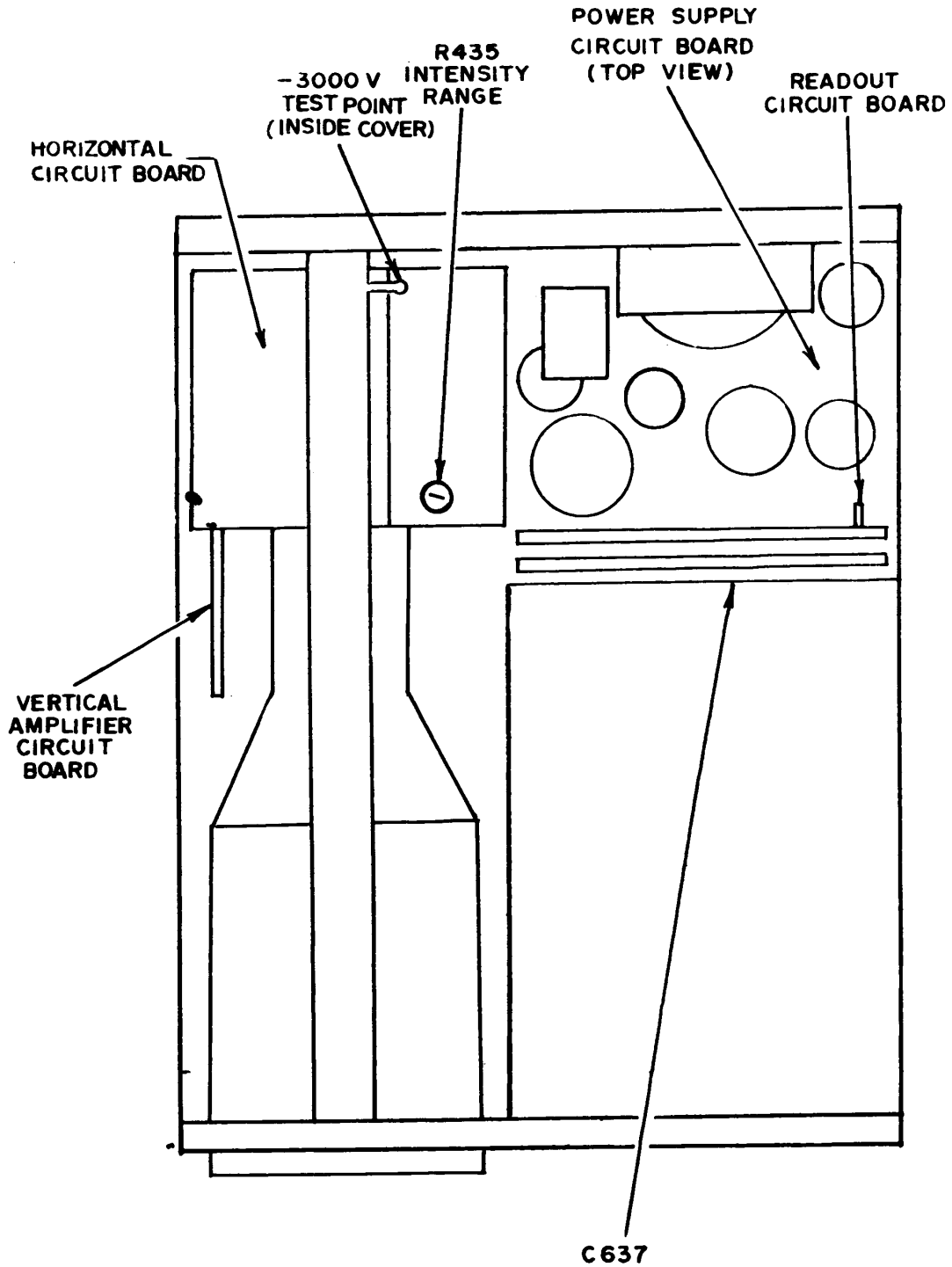

Figure 1. TI circuit board locations.

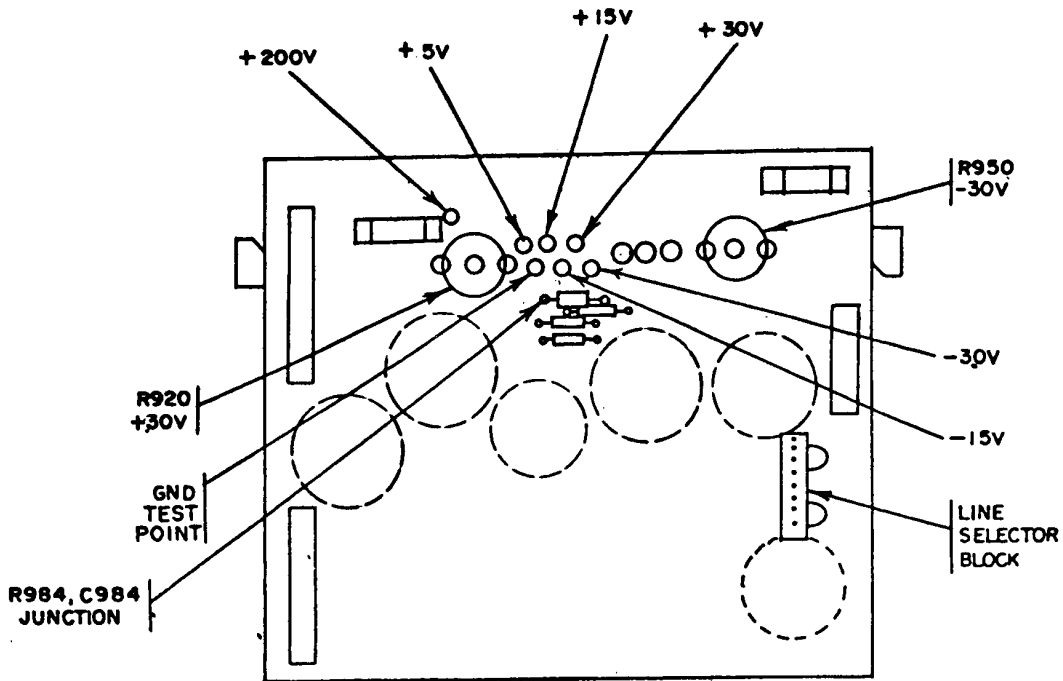

Figure 2. Power supply circuit board (bottom).

- (2) FOCUS control to midrange.
 - (3) POWER switch to on.
 - (4) GRAT ILLUM control as desired.
 - (5) READOUT INTENS control to midrange.
- g.** Allow approximately 15 minutes for the TI to warmup and stabilize.

SECTION IV CALIBRATION PROCESS

NOTE

Unless otherwise specified, verify the results of each test and, whenever the test requirement is not met, take corrective action before continuing with the calibration. Adjustments required to calibrate the TI are included in this procedure. Additional maintenance information is contained in the manufacturer's manual for this TI.

NOTE

When indications specified in paragraphs **8** through **20** are not within tolerance, perform the power supply checks prior to making adjustments. After adjustments are made, repeat paragraphs **8** through **20**. Do not perform power supply checks if all other parameters are within tolerance.

8. Calibrator Output Voltage

a. Performance Check

(1) Press TI POWER switch to off and connect probe(B3)between the junction of R984 and C984, and GND TEST POINT (fig. 2),using adapter (B1).

(2) Connect digital voltmeter (A3) between TI. CALIBRATOR current loop and GND TEST POINT, using adapters and leads supplied With digital voltmeter.

(3) Pull TI POWER switch to on.

(4) Digital voltmeter should indicate between +396 and +404 mV (millivolts) dc.

(5) Vary autotransformer (A1) between 105 and 125 V ac and observe that digital voltmeter indication remains between +396 and +404 mV dc.

(6) Press TI POWER switch to off and disconnect probe and adapter connected in (1) above.

(7) Pull TI POWER switch to on.

(8) Connect CALIBRATOR loop to vertical amplifier channel 1 INPUT, using adapter and probe (B4 and B3).

(9) Adjust INTENSITY control, vertical amplifier VOLTS/DIV switch, and time base TIME/DIV switch as necessary to obtain a square wave display.

b. Adjustments. No adjustment can be made.

9. Intensity Range

a. Performance Check. Slowly adjust TI INTENSITY control cw (clockwise) until trace appears on TI screen. If the TI INTENSITY control is not between its 8 and 11 o'clock position, perform **b** below.

b. Adjustment. Turn TI INTENSITY control fully ccw and adjust INTENSITY RANGE R435 (fig. 1) until trace is just visible and then readjust until trace is just extinguished.

10. Focus and Astigmatism

a. Performance Check

(1) Position vertical amplifier (A6) controls as listed in (a) through (d) below:

- (a) Channel 1 POSITION control to midrange,
- (b) Channel 1 INPUT COUPLING switch to DC.
- (c) MODE switch to CH1.
- (d) TRIGGER switch to CH1.

(2) Position time base (A4) controls, as listed in (a) through (e) below:

- (a) Main triggering:
 - 1 SLOPE switch to +.
 - 2 Mode switch to AUTO TRIG.
 - 3 TRIGGER SOURCE switch to LEFT.
- (b) POSITION control as desired.
- (c) SWP MAG. switch to X1 (out).
- (d) MAIN SEC/DIV switch to 1 ms.
- (e) DISPLAY MODE switch to MAIN SWP.

(3) Adjust TI INTENSITY control for a normal display.

(4) Set time base MAIN SEC/ DIV switch to AMP (fully ccw) and adjust TI FOCUS control fully cw. If displayed spot on TI screen is not round, perform **b** below. It may be necessary to readjust INTENSITY control.

(5) Set time base MAIN SEC/DIV switch to 1 ms.

b. Adjustments. Adjust ASTIG R370 (fig. 3) and TI FOCUS control simultaneously to obtain best defined spot on TI screen.

11. Trace Alignment

a. Performance Check. Adjust vertical amplifier (A6) and time base (A4) POSITION controls to center trace on TI horizontal graticule line. If trace is not aligned with TI center horizontal graticule line, perform **b** below.

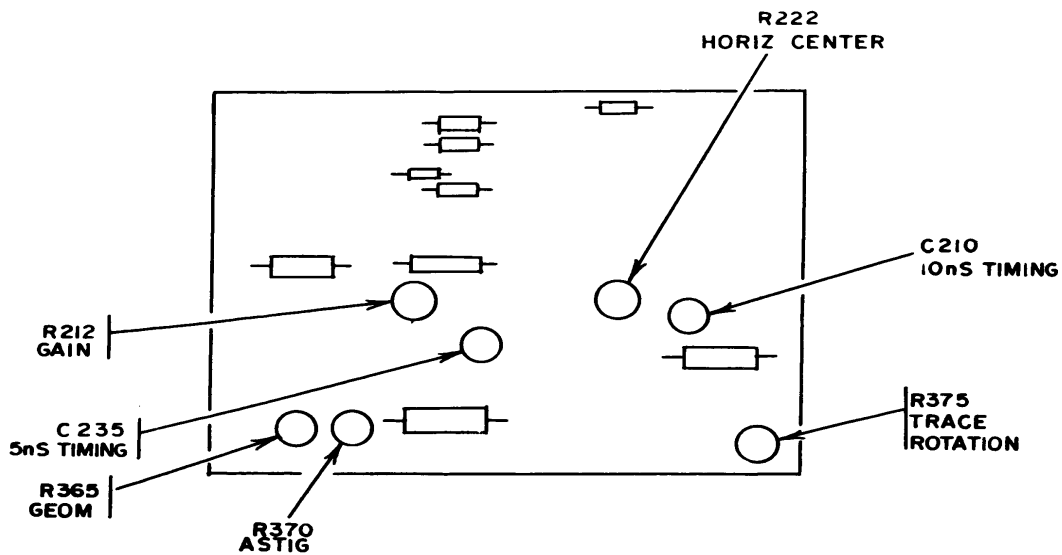

Figure 3. Horizontal circuit board (top).

b. Adjustment. Adjust TRACE ROTATION R375 (fig. 3) until trace is aligned with TI center horizontal graticule line.

12. Geometry

a. Performance Check

- (1) Press TI POWER switch to off.
- (2) Remove time base (A4) from TI right compartment and install in center compartment.
- (3) Remove vertical amplifier (A6) from TI left compartment and install in right compartment.
- (4) Pull TI POWER switch to on.
- (5) Adjust TI FOCUS and INTENSITY controls for a well defined trace that extends vertically above and below graticule area.
- (6) Adjust vertical amplifier POSITION control to move TI trace across entire graticule area. If trace bows or tilts greater than 0.1 division anywhere on graticule area, perform **b** below.

b. Adjustment. Adjust GEOM R365 (fig. 3) for minimum bowing or tilt of trace at left and right edges of graticule. It may be necessary to readjust R365 to obtain less than 0.1 division of bowing and tilt everywhere on graticule area.

TB 9-4931-501-35

13. Vertical Centering

a. Performance Check

- (1) Press TI POWER switch to off.
- (2) Install calibration fixture (A2) in TI left compartment.
- (3) Remove vertical amplifier (A6) from TI right compartment and remove time base (A4) from center compartment.
- (4) Install time base in TI right compartment and pull TI POWER switch to on.
- (5) Position calibration fixture controls as listed in (a) through (d) below:
 - (a) POSITION control to midrange.
 - (b) AMPLITUDE control to midrange.
 - (c) TEST switch to COM MODE.
 - (d) REP RATE switch to 100 kHz (kilohertz).
- (6) If trace is not within 0.5 division of the center horizontal graticule line, perform **b** below.
- (7) Press TI POWER switch to off and move calibration fixture from left to center vertical compartment.
- (8) Pull TI POWER switch to on. If trace is not within ± 0.5 division of center horizontal graticule line, repeat (b) below for a compromise between left and center vertical compartments.

b. Adjustments. Adjust VERT CENTER R135 (fig. 4) to position trace to horizontal graticule line.

14. Vertical Gain

a. Performance Check

- (1) Press TI POWER switch to off and install calibration fixture (A2) in TI left compartment.
- (2) Pull TI POWER switch to on.
- (3) Set calibration fixture TEST switch to VERT OR HORIZ GAIN and REP RATE switch to 1 MHz.

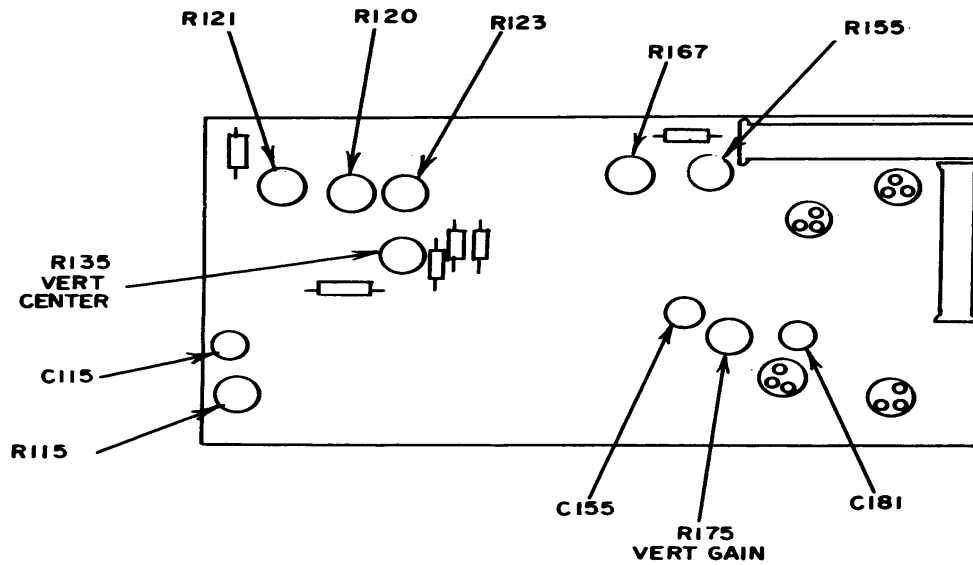

Figure 4. Vertical amplifier circuit board (left side).

(4) Adjust calibration fixture POSITION control to align bright center trace of display with TI center horizontal graticule line.

(5) If center seven traces do not coincide within ± 0.1 division of respective horizontal graticule lines, perform **b** below.

(6) Press TI POWER switch to off and remove calibration fixture from left and install in TI center compartment.

(7) Pull TI POWER switch to on and repeat (4) and (5) above and if necessary, repeat b below for optimum gain setting compromise for both vertical compartments.

b. Adjustments. Adjust VERT GAIN R175 (fig. 4) for a 6-division deflection over center seven horizontal graticule lines (R).

15. Vertical Compensation

a. Performance Check

(1) Press TI POWER switch to off. Remove calibration fixture (A2) from center and install in TI left compartment. Pull TI POWER switch to on.

(2) Set calibration fixture TEST switch to VERT OR HORIZ + STEP RESP and REP RATE switch to 100 kHz. Adjust AMPLITUDE and POSITION controls for a 6-division display centered vertically on TI graticule.

(3) Position time base (A4) controls as listed in (a) through (f) below:

(a) MAIN SEC/DIV switch to 2 μ s (microsecond).

(b) VARIABLE control to CAL.

(c) AUTO TRIG switch in.

(d) AC COUPL switch in.

(e) POSITION control to center display.

(f) MAIN TRIG LEVEL control for a stable display, triggered on the rising portion of the pulse.

(4) If pulse displayed does not have a flat top and square leading corner (aberrations less than 0.36 division), perform **b**(1) through (4) below.

(5) Set calibration fixture REP RATE switch to 1 MHz.

(6) Set time base MAIN SEC/DIV switch to 0.1 and, adjust MAIN TRIG LEVEL control for a stable display triggered on rising portion of the pulse.

(7) If pulse displayed on TI does not have a square leading corner and aberrations are not less than 0.36 division, perform **b**(5) below.

(8) Press TI POWER switch to off and remove calibration fixture from left and install in TI center vertical compartment. Set time base TRIG SOURCE switch to RIGHT.

(9) Pull TI POWER switch to on and repeat (2) through (7) above. If necessary, compromise vertical compensation adjustments for TI left and center vertical compartments.

b. Adjustments

(1) Adjust R121 (fig. 4) for optimum flat top on pulse displayed on TI screen.

(2) Set time base MAIN SEC/DIV switch to 1 μ s and adjust R120 (fig. 4) for optimum flat top on displayed pulse.

(3) Set time base MAIN SEC/DIV switch to 0.5 μ s and adjust R123 (fig. 4) for optimum flat top on displayed pulse.

(4) Repeat (1) through (3) above as necessary to obtain optimum flat top on displayed pulse.

(5) Adjust C637 (fig. 1) (main interface board between vertical compartments, serial number B063251 and up), C115, R115, C155, R155, R167, and C181 (fig. 4) for optimum pulse display on TI screen.

NOTE

There is interaction between C115 and R115, and between C155 and R155. Readjust if required.

16. Risetime

NOTE

Perform paragraphs **17**, **18**, and **19** before performing paragraph **16**.

a. Performance Check

(1) Adjust calibration fixture (A2) AMPLITUDE and POSITION controls for a convenient display centered on TI crt graticule.

(2) Position time base (A4) controls as listed in (a) through (c) below:

(a) MAIN SEC/DIV switch to .1 μ .

(b) SWP MAG switch in.

(c) MAIN TRIG LEVEL control for stab display

(3) Measure risetime, using standard risetime technique. Risetime will be 4 ns (nanoseconds) or less.

(4) Press TI POWER switch to off. Move calibration fixture to TI left compartment. Pull TI POWER switch to on.

(5) Press time base TRIG SOURCE LEFT switch and adjust MAIN TRIG LEVEL control for stable display. Repeat (3) above.

b. Adjustments. No adjustment can be made.

17. Horizontal Centering

a. Performance Check

(1) Press TI POWER switch to off. Install calibration fixture (A2) in TI right compartment and time base (A4) in left compartment.

(2) Position calibration fixture controls as listed in (a) through (d) below:

- (a) POSITION control to midrange.
- (b) AMPLITUDE control to midrange.
- (c) TEST switch to COM MODE.
- (d) REP RATE switch to 1 MHz.

(1) Pull TI POWER switch to on. If a vertical trace is not displayed within ± 0.5 division of TI center vertical graticule line, perform **b** below.

b. Adjustments. Adjust HORIZ CENTER R222 (fig. 3) to position trace to TI center vertical graticule line.

18. Horizontal Gain

a. Performance Check

(1) Set calibration fixture (A2) TEST switch to VERT OR HORIZ GAIN and adjust POSITION control to align bright center trace on TI with center vertical graticule line.

(2) If center seven traces do not coincide within ± 0.25 division of respective vertical graticule lines, perform **b** below.

b. Adjustments. Adjust GAIN R212 (fig. 3) for a 6-division deflection over center seven vertical graticule lines (R).

19. 10 and 5 ns Timing

a. Performance Check

(1) Press TI POWER switch to off. Install calibration fixture (A2) in TI left compartment and time base (A4) in right compartment. Pull TI POWER switch to on.

(2) Set calibration fixture TEST switch to AUX IN.

(3) Connect time mark generator (A5) output to calibration fixture AUX IN, and time mark generator TRIGGER OUTPUT to time base EXT TRIG, using two cables (B2).

(4) Set time mark generator marker output to 10 ns (nanoseconds) and trigger output to 1 μ s. Adjust calibration fixture AMPLITUDE control for convenient display on TI screen.

(5) Position time base controls as listed in (a) through (f) below:

(a) AUTO TRIG switch in.

(b) MAIN SEC/DIV switch to 0.1 μ s.

(c) SWP MAG switch in.

(d) TRIG SOURCE LEFT and EXT switches in.

(e) MAIN TRIG LEVEL control for a stable display on TI screen.

(f) POSITION control to align fourth time marker with second vertical graticule line on TI.

(6) If the 12th time marker is not within ± 2.5 minor divisions of 10th vertical graticule line, perform **b(1)** below.

(7) Set time mark generator output to 5 ns and adjust calibration fixture AMPLITUDE control for convenient display on TI.

(8) Adjust TI MAIN TRIG LEVEL control for a stable display and time base POSITION control to align seventh time marker with second vertical graticule line on TI screen.

(9) If 23d time marker is not within ± 3 minor divisions of 10th vertical graticule line, perform **b(2)** and (3) below.

b. Adjustments

(1) Adjust 10 ns TIMING C210 (fig. 3) for one time marker per division over center eight vertical graticule lines (R).

(2) Adjust 5 ns TIMING C235 (fig. 3) for two time markers per division over center eight vertical graticule lines (R).

(3) Due to interaction between C210 and C235, repeat **a(4)** through (9) above to obtain best timing compromise.

20. Readout System

NOTE

Perform paragraph **16** before continuing.

a. Performance Check

(1) Press TI POWER switch to off. Remove calibration fixture (A2) and time base (A4) from TI compartments.

(2) Remove Q1040 (fig. 5).

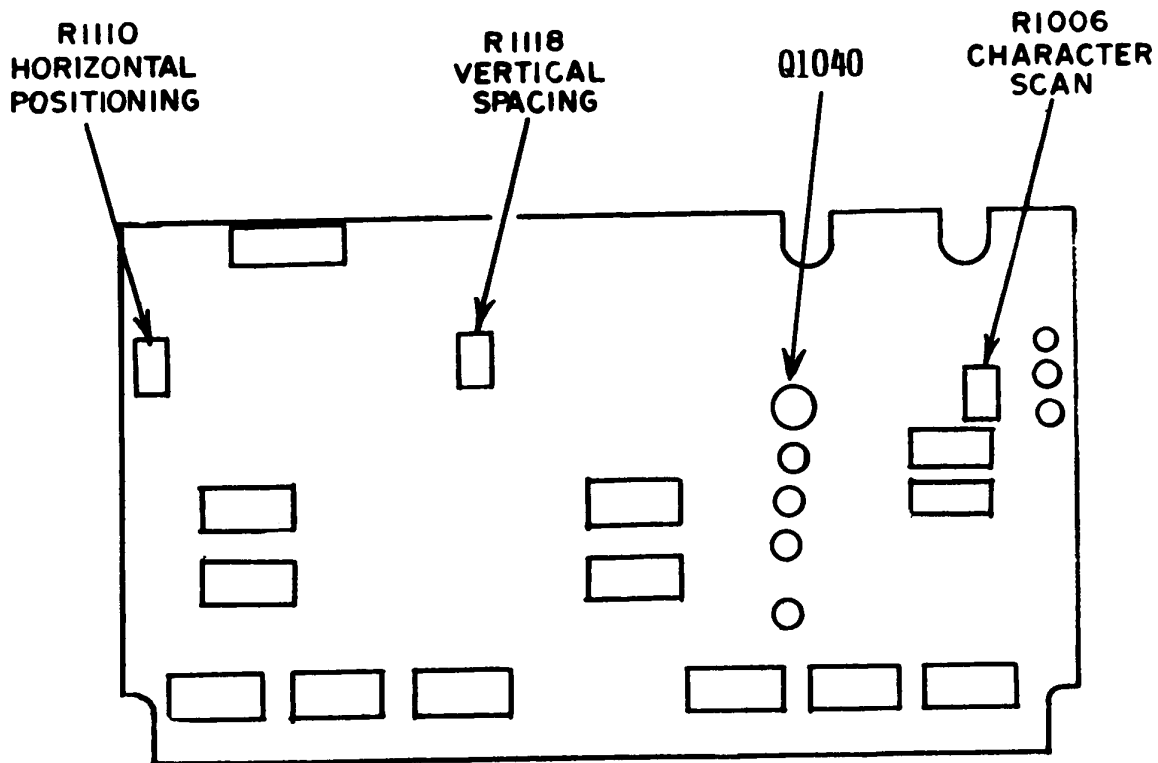

Figure 5. Readout circuit board (top).

(3) Pull TI POWER switch to on and adjust READOUT control for visible characters.

(4) If TI does not display two rows of zeros located in middle of top and bottom graticule divisions, with 4 zeros in each row with no overlap, perform **b(1)** below.

(5) If the first and last zero of both rows are not within the TI graticule area, perform **b(2)** below.

(6) If zeros are not complete or have overscanning, (overscanning causes a bright dot where traces overlap) perform **b**(3) below.

(7) Set TI POWER switch to off and install Q1040.

b. Adjustments

(1) Adjust VERT CENTER R135 (fig. 4) to position the bottom row of zeros to the middle of the TI screen bottom graticule division. Adjust VERTICAL SPACING R1118 (fig. 5) to position the top row of zeros to the middle of the TI screen top graticule division. Due to interaction, it may be necessary to readjust R135 and R1118 until correct zero location is obtained.

(2) Adjust HORIZONTAL POSITIONING R1110 (fig. 5) until first and last zero of both rows arc within TI graticule.

(3) Adjust CHARACTER SCAN R1006 (fig. 5) for fully scanned zeros without overscanning. Turn TI POWER switch to off, and install transistor Q1040.

21. Power Supply

NOTE

Do not perform power supply checks if all other parameters arc within tolerance.

a. Performance Check

(1) Install vertical amplifier (A6) in TI left compartment and time base (A4) in right compartment. Pull TI POWER switch to on.

(2) Connect digital voltmeter (A3) between test point -30 V (fig. 2) and chassis ground, using adapters and leads supplied with digital voltmeter.

(3) If digital voltmeter does not indicate between -29.925 and -30.075 V dc, perform **b**(1) below.

(4) Connect digital voltmeter between test point +30 V (fig. 2) and chassis ground.

(5) If digital voltmeter does not indicate between +29.925 and +30.075 V dc, perform **b**(2) below.

(6) Connect digital voltmeter between voltage test points listed in table 4 and chassis ground. Digital voltmeter indications should be within limits specified in table 4.

Table 4. Power Supply Check

Test instrument voltage test points (fig. 2)	Digital voltmeter indications (V dc)	
	Min	Max
-15 V	-14.85	-15.15
+5 V	+4.9	+5.1
+15 V	+14.85	+15.15
+200	+180	+220

(7) Press TI POWER switch to off. Remove the time base from the right compartment and install vertical amplifier into the right compartment.

(8) Remove the high voltage cover and connect digital voltmeter between -3000 V TEST POINT (fig. 1) and chassis ground, using high voltage probe supplied with digital voltmeter.

(9) Pull TI POWER switch to on. Digital voltmeter should indicate between -2940 and -3060 V dc.

(10) Press TI POWER switch to off and replace high voltage cover.

b. Adjustment

(1) Adjust -30 V R950 (fig. 2) until digital voltmeter indicates -30 V dc (R).

(2) Adjust +30 V R920 (fig. 2) until digital voltmeter indicates +30 V dc (R).

22. Final Procedure

a. Deenergize and disconnect all equipment and reinstall TI protective cover.

b. In accordance with TM 38-750, annotate and affix DA Label 80 (US Army Calibrated Instrument). When the TI receives limited or special calibration, annotate and affix DA Label 163 (US Army Limited or Special Calibration). When the TI cannot be adjusted within tolerance, annotate and affix DA Form 2417 (US Army Calibration System Rejected Instrument).

TB 9-4931-501-35

By Order of the Secretary of the Army:

E. C. MEYER
General, United States Army
Chief Of Staff

Official:

J. C. PENNINGTON
Major General, United States Army
The Adjutant General

Distribution:

To be distributed in accordance with DA Form 12-34A. (qty rqr block No. 74), requirements for calibration procedure publications.

US GOVERNMENT PRINTING OFFICE: 1979 - - 640042/1486

PIN NO.: 032019-006